

Model 267 Pulse/CW TWT Amplifier

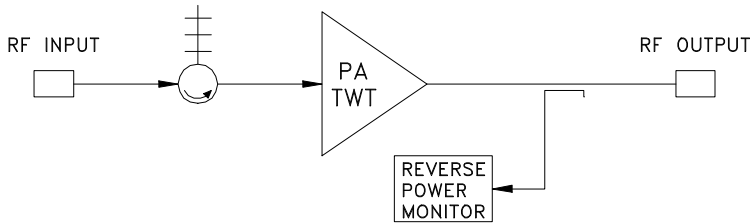

The Model 267 is a dual mode Pulse/CW TWT Amplifier which has been designed to operate TWT's up to 80 watts in the 18 to 26.5 and 26.5 to 40 GHz frequency ranges. The RF output pulse is generated by the focus electrode (grid) pulse. CW operation may be selected by a discrete signal or by the application of +5VDC on the pulse input terminal. RF output pulse is controlled by the input video pulse.

Internal power supplies are DC-DC converter designs with fast loop response times so that output level variations are minimal for any PRF including a non-periodic or burst type PRF. The modular power supplies and grid pulse generator have very low ripple, with attendant low phase noise in the TWT Amplifier.

The modular design of the Model 267 provides convenient accessibility to all elements in the TWT amplifier. Plug-in PC boards are accessible through the front panel. The PC card cover contains a legend for PC card located test points and controls. High voltage modules are encapsulated, plug-in assemblies. There is no exposed high voltage.

FEATURES:

- Frequency 18-26.5 or 26.5-40 GHz
- Low Spurious Outputs
- Phase and Amplitude Stability
- RF Output Fidelity
- Complete TWT Protection
 - PRF Limit
 - Helix Overcurrent
 - Cathode Over/Undervoltage
 - Filament Low Voltage
 - Overtemperature
 - Input Energy Limit
 - Reverse Power Monitor
- Custom Requirements
- Solid State Except for the TWT
- Front Panel Voltage Adjustments
- Front Panel Fault Isolation
- Modular Construction
- DC TWT Filaments
- Four Line Display
 - Operating Mode
 - Cathode Voltage
 - Helix Current
 - Filament and Operate Time
- Front Panel Controls
 - Power On / Off
 - Operate
 - Standby
 - Fault Reset
 - Local / Remote
 - Pulse / CW

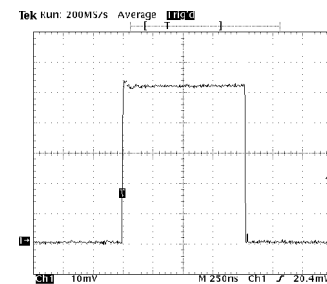

Detected RF Output



APPLIED SYSTEMS ENGINEERING, INC.

FORT WORTH, TEXAS

Model 267 TWT Amplifier

SPECIFICATIONS

Duty Cycle	Up to 50% Pulse or CW
Pulse Width Range	50 ns to CW
PRF Range	100 kHz
RF Rise / Fall Time	15 ns, Maximum
RF Pulse Droop	< 0.1 dB, Maximum
Delay, Input to RF	200 ns, Maximum
Phase Noise	< $\pm 1^\circ$ pk to pk
Amplitude Variation	0.1 dB, Maximum
Spurious Outputs	-50 dBc, Maximum
Input Pulse	5 Volts into 50 ohms
Noise Figure	35 dB, Nominal
RF Connectors	Waveguide
Primary Power	120/220/240 VAC $\pm 10\%$, 50/60 Hz
Operating Temperature	0 to 50 $^\circ$ C
Weight	90 lbs, Nominal
Dimensions	8.75x19x28.5 (in.)

Standard Equipment

- Input Isolator
- RF Input - K, RF Output - WR-28
- Filament / Operate Time
- IEEE-488 Remote Interface
- Reverse Power Monitor
- Switchable Pulse or CW Mode of Operation

Options

- Driver Amplifier
- RF Sample Ports
- Forward/Reverse Power Meter
- RS-232/422 Remote Interface
- Other Primary Power
- Outdoor Enclosure
- RF Connectors on Front Panel

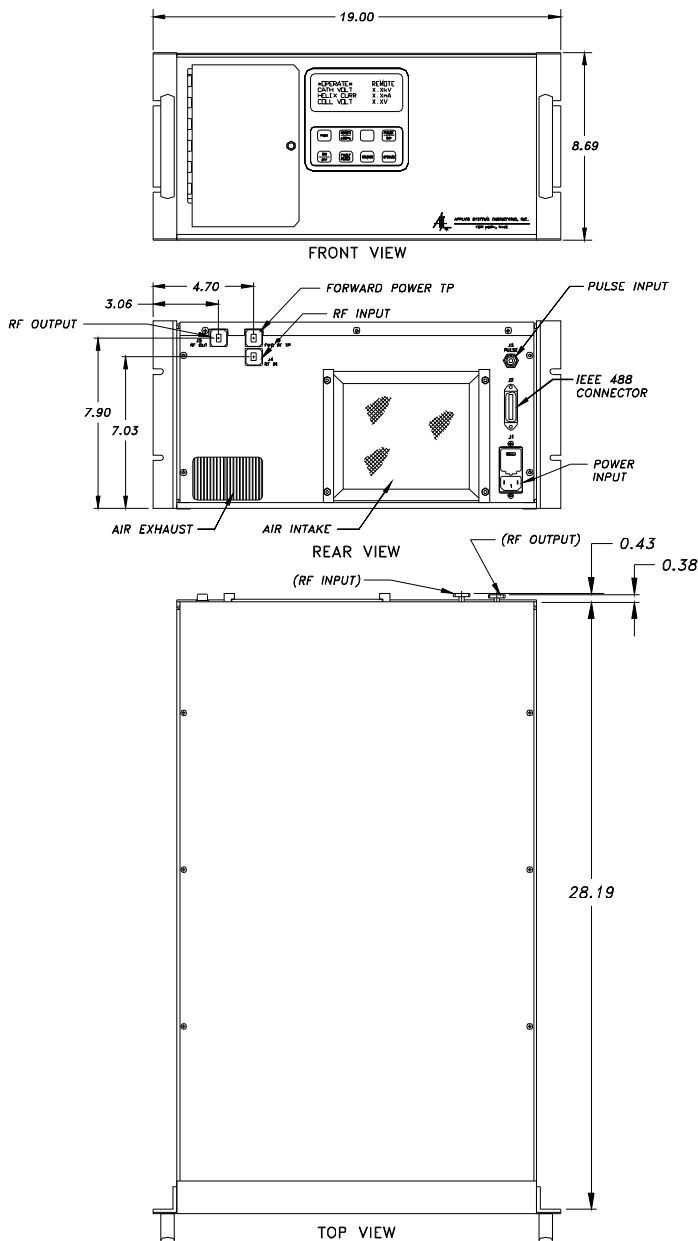

APPLIED SYSTEMS ENGINEERING, INC.

PO BOX 122987 FORT WORTH TEXAS 76121
TELEPHONE: (817) 249-4180 FAX: (817) 249-3413

mdl267_3.wpd
01-21-09